

SEDIMAX™ SEDIMENT RETENTION

INSTALLATION GUIDE



- ▶ North American Green SediMax™ Systems are quicker to install than straw bales and silt fence resulting in lower project costs.

SediMax™ Installation Guidelines

North American Green SediMax™ Systems can prevent damage and save millions of dollars spent on restoring slopes, rebuilding drainage channels and dredging ponds and streams. Even better is the fact that these products are easy to install. The following guidelines are provided to assist in design, installation and structure spacing. These guidelines may require modification due to variation in soil type, rainfall intensity or duration, and amount of runoff affecting the application site.

To begin, SediMax System products should be installed perpendicular to the primary direction of overland flow. To maximize sediment containment with SediMax Systems, place the initial structure at the top/crest of the slope if significant runoff is expected from above. If no runoff from above is expected, the initial SediMax product can be installed at the appropriate distance downhill from the top/crest of the slope. The final structure should be installed at or just beyond the bottom/toe of the slope.

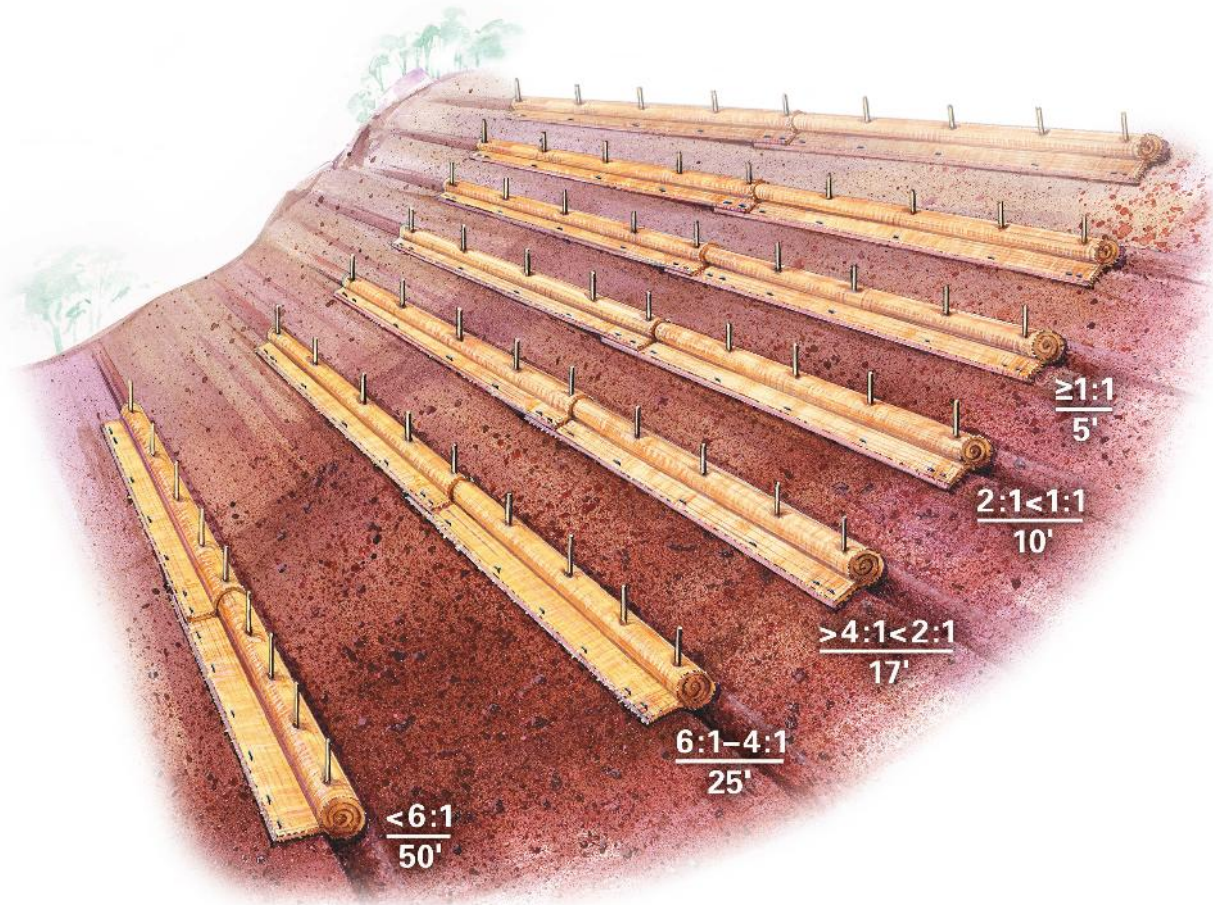

SediMax rolls should be installed along the slope contour with spacing based on slope grade.



SEDIMAX-FR™ (FILTRATION ROLLS)

SediMax-FR™ (Filtration Rolls), formerly known as SedimentSTOP, are easy to install and feature a two- to three-year functional lifespan. The structurally sound net-reinforced layers prevent failures – even if the outer netting wrap is damaged during or after installation.

SediMax-FR is easily field fabricated for greater flexibility to specific site requirements. They are extremely flexible and readily conform to the ground surface, minimizing undercutting. Longer, 50 ft finished roll length reduces the number of overlaps, and its leno-woven natural jute net allows easier contouring to the soil. The short, lightweight packaged rolls are easily transported over difficult terrain and to remote areas. Finished roll diameter can also be increased, if necessary, by simply adding other organic materials such as grass clippings, pine needles, straw or leaves.

The following steps are recommended for successful SediMax-FR Installation.

SEDIMAX-FR INSTALLATION STEPS:

1. Begin at the location where the SediMax-FR is to be installed by excavating a 3 in. (7.5 cm) deep x 9 in. (22.9 cm) wide trench along the contour of the slope. Excavated soil should be placed upslope from the anchor trench (Figure 1).

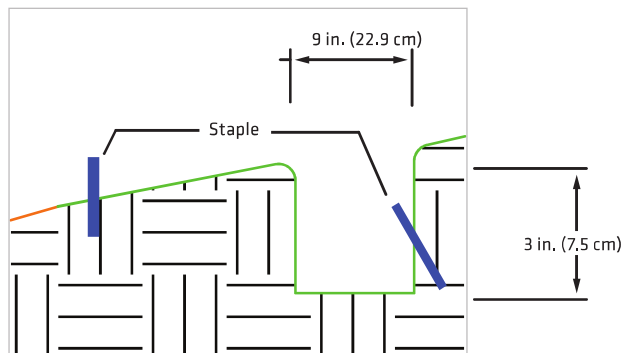

FIGURE 1

2. Unroll the SediMax-FR so the section with the 2 ft wide top netting is the downslope end (splash apron). The splash apron of the SediMax-FR should cover the anchor trench ensuring that approximately 12 in. (30 cm) is extended beyond the lower edge of the anchor trench (Figure 1).

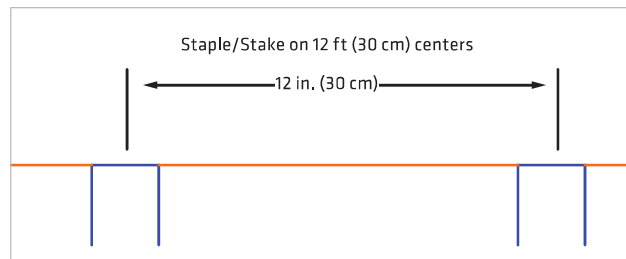

FIGURE 2

3. Secure the SediMax-FR in the anchor trench by placing a row of staples/stakes on 12 in. (30 cm) centers across the entire length of the SediMax-FR. A second row of staples/stakes must be placed across the entire lower edge of the SediMax-FR splash apron on approximately 12 in. (30 cm) centers, staggered with the first row of staples/stakes (Figures 1 and 2).



4. Begin rolling the SediMax-FR™ from its upper edge (upslope edge) into a consistent roll diameter until the roll is located in the anchor trench. If a larger diameter structure is desired, place additional organic material (i.e., straw, leaves, pine needles or lawn clippings) across the entire width of the SediMax-FR prior to rolling. (Figures 3A and 3B) (See Figure 4 for seaming of adjacent SediMax-FR rolls.)

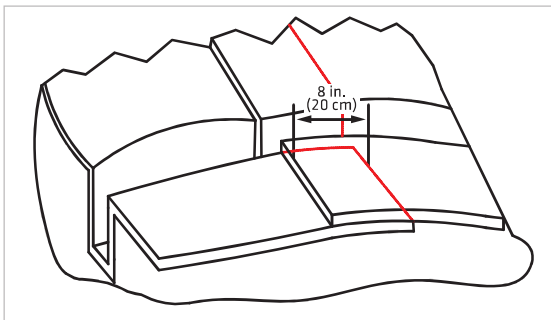

FIGURE 3A

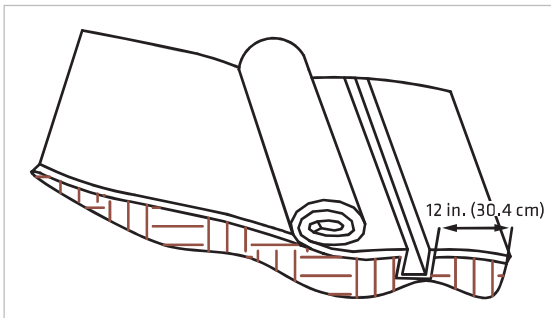

FIGURE 3B

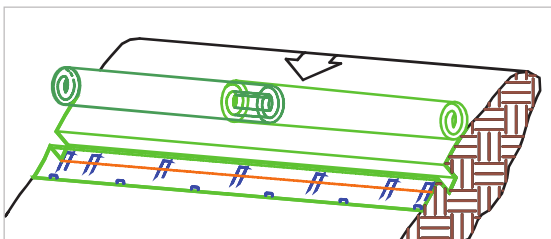

FIGURE 4

5. Stop rolling the SediMax-FR when the roll is located in the anchor trench.
6. Secure the SediMax-FR structure to the slope surface by driving 18 to 24 in. (45-60 cm) minimum stakes through the center of the roll every 3 ft (0.9 m) on center. If two SediMax-FR structures are seamed together ensure a stake is driven through the seam. The final structure's diameter will dictate stake length. Leave a sufficient amount of stake exposed above the SediMax-FR to ensure the structure is not compressed. Both longitudinal ends should be angled upslope (Figure 5).

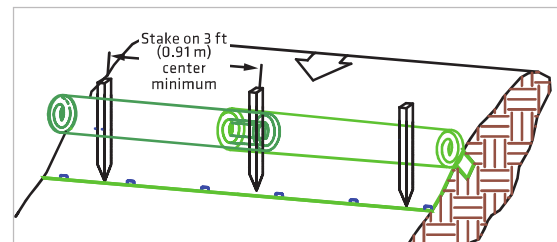

FIGURE 5

7. Backfill and compact soil into the upslope portion of the anchor trench. Smooth and level any soil remaining above the SediMax-FR not used to fill the anchor trench. Place seed along upslope portion of SediMax-FR if required (Figure 6).

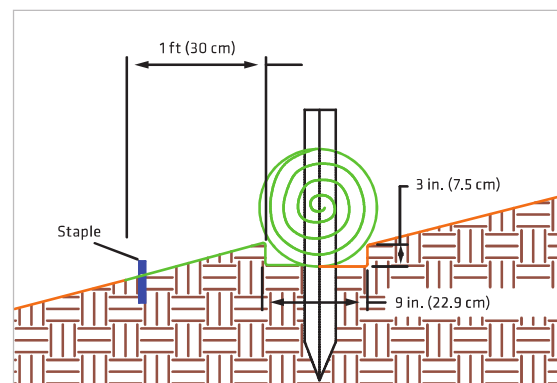

FIGURE 6

SEDIMAX-SW™ (STRAW WATTLES)

North American Green SediMax-SW™ (Straw Wattles), are a Best Management Practice (BMP) that offers an effective and economical alternative to silt fence and straw bales for sediment control and storm water runoff.

Straw Wattles are a temporary sediment control device and are not intended to replace Rolled Erosion Control Products (RECPs) or Hydraulic Erosion Control Products (HECPs). If vegetation is desired for permanent erosion control, North American Green recommends that RollMax™ or HydraMax™ Systems be used to provide effective immediate erosion control until vegetation is established. SediMax™ Systems may be used in conjunction with blankets, mats and mulches as supplemental sediment and runoff control for these applications. Like all sediment control devices, the effectiveness of SediMax Systems is dependent on storage capacity.

SEDIMAX-SW INSTALLATION STEPS:

1. Begin at the location where the wattle is to be installed by excavating a 2 to 3 in. (5-7.5 cm) deep x 9 in. (22.9 cm) wide trench along the contour of the slope. Excavated soil should be placed upslope from the anchor trench (Figure 7).

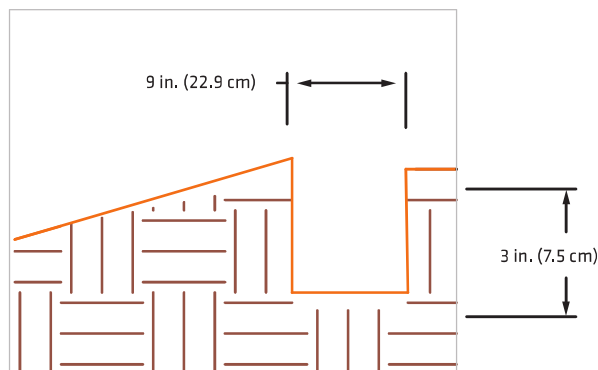

FIGURE 7

2. Place the wattle in the trench so that it contours to the soil surface. Compact soil from the excavated trench against the wattle on the uphill side. Wattles should tightly abut (Figure 8).

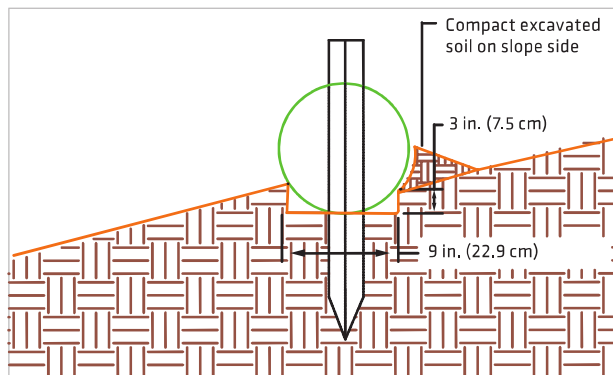

FIGURE 8

3. Secure the wattle with a minimum of 18 to 24 in. (45.7-61 cm) stakes every 3 to 4 ft (0.9 -1.2 m) and with a stake on each end. Stakes should be driven through the middle of the wattle leaving at least 2 to 3 in. (5-7.5 cm) of stake extending above the wattle (Figure 9). Stakes should be driven perpendicular to the slope face. Spacing of SediMax-SW on slope will vary based on the slope grade (Figure 10).

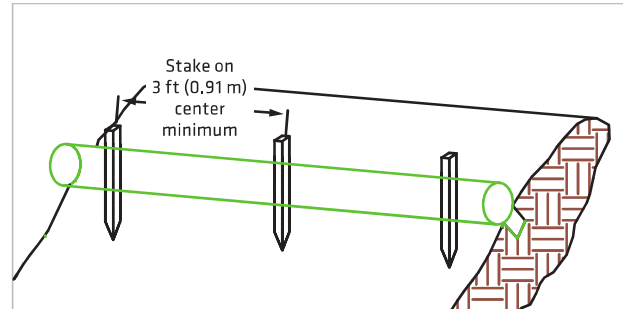

FIGURE 9

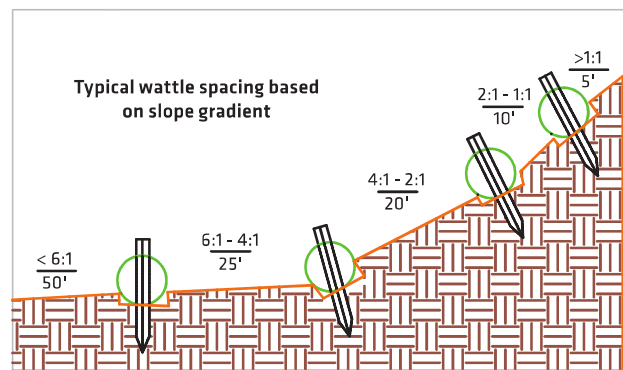

FIGURE 10

For additional installation assistance on SediMax Systems, please call **800-772-2040**, visit **nagreen.com** or e-mail **info@nagreen.com** and we will be happy to put you in touch with your erosion control specialist who can assist you.



North American Green
5401 St. Wendel-Cynthiana Road
Poseyville, Indiana 47633

nagreen.com
800-772-2040

Distributed by:

©2017, North American Green is a registered trademark. Certain products and/or applications described or illustrated herein are protected under one or more U.S. patents. Other U.S. patents are pending, and certain foreign patents and patent applications may also exist. Trademark rights also apply as indicated herein. Final determination of the suitability of any information or material for the use contemplated, and its manner of use, is the sole responsibility of the user. Printed in the U.S.A.